

Emperical Study of Passive Optcal Networks

"Neetu Singh, "Vikas Malik

¹M.Tech. Student, Electronics & Communication Engineering, P.D.M.College, Bahadurgarh, India
²A.P., Dept. of Electronics & Communication Engineering, P.D.M.College, Bahadurgarh, India

Abstract

Passive Optical networks (PON) is one of the best option for access of fiber to home as it provides high bandwidth as well as it is cost effective. However, the main issue arise in the EPON system nowadays is the bandwidth allocation. There is numerous research works that is able to allocate the upstream bandwidth dynamically to the optical network units (ONUs). To achieve good network performance and thus provide guaranteed network service to end users, an EPON system must employ an efficient bandwidth allocation algorithm to dynamically allocate the limited bandwidth of the upstream transmission upstream channel among multiple optical network units (ONUs). In this paper, various efficient bandwidth allocation algorithm for an EPON system are proposed. The proposed algorithms use the multipoint control protocol (MPCP) defined by the IEEE802.3ah Task Force to attribute the transmission of multiple ONUs, and incorporate a dynamic bandwidth allocation (DBA)scheme that makes use of the excessive bandwidth of lightly loaded ONUs to meet the bandwidth demand of heavily loaded ONUs. To improve bandwidth utilisation under high traffic load, an effective scheduling control mechanism are also incorporated to address the idle period problem and significantly improve the network performance in terms of packet delay, queue length and throughput under high traffic load as compared with a well-known DBA algorithm in the literature

Keywords

Optical Line Termination (OLT), Optical Network Units (ONU), Passive Optical Splitter (PON).

I. Introduction

Telecommunications today is perhaps the fastest evolving field of study. It is continuously offering new challenges and opportunities to telecommunications network planners. The subscriber part of the telecommunications network or the network connecting the subscribers to the central office or the access network that has been traditionally simple twisted copper pair based, point to point, passive network is now becoming increasingly complex. In the present scenario it becomes imperative for the access network planner to be familiar with both traditional and new technologies, structures and methods as their plans would have a profound long term impact on how the network shapes up and meets the desired objectives. The basic idea of telecommunication is the exchange of information. The information may include voice, text, data, image and video. A telecommunications network is therefore a system which can provide these services to a number of end users. It is very important for network planners to pay attention to the technical evolution of telecommunication systems. This would to enable proven new technologies to provide high quality telephone service and meet demands of new telecommunication services. Owing to prospective development of these technologies and increasing demand for new services other than telephony, telecommunication networks are changing from partly analog to fully digital. Demand and traffic patterns will change faster in the future than they do today. To cope with this, one important property a network should have is flexibility. Flexibility in simple term implies being able to provide bandwidth on demand. If bandwidth

can be provided on demand then the network becomes capable of deploying and supporting a wide variety of services and with greater ease and speed.

II. Access Networks

It is that part of a telecommunications network which connects subscribers to their immediate service provider. The term access network refers to the network between the local exchange and the subscriber. In many countries this network is still predominantly made up of the copper cable based point to point connections[1]. The technology has not changed much during the last many decades even though considerable changes have been introduced in the field of switching and transport.

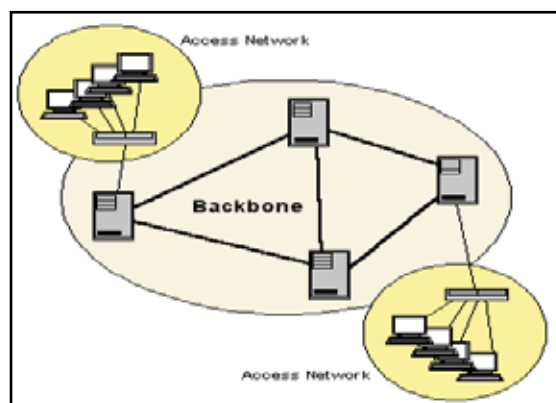

Fig.1 : The Access Network

Name	Meaning	Data Rate	Connection Type	Applications
DSL	Digital subscriber Line	160kb/s	Symmetrical	ISDN series, voice and data comm.
HDSL	High Data Rate Digital Subscriber Line	2Mb/s	Symmetrical	No POTS, E1 LAN/WAN, Service access feeder plant.
SDSL	Single Line Digital Subscriber Line	2Mb/s	Symmetrical	Same as HDSL + POTS
ADSL	Asymmetric Digital Subscriber Line	1.5 to 8Mb/s Down 128kb-768kb Up	Asymmetrical	Interest access, video on demand, simplex video, remote LAN access, interactive multimedia.
VDSL	Very High Data Rate Digital Subscriber Line	13-52Mbps Down 1.5-2.3Mbps Up	Asymmetrical	Same as ADSL plus HDTV

With the advent of digital technology, the process of installation, maintenance has become less cumbersome and quality of services has improved. It is therefore felt that the any cause for dissatisfaction, among customers about present services, is predominantly due to the frequent failures in the access network and the time taken for restoring them. One of the most fundamental and remarkable of the driving technologies of today is the optical fibre. Without it the current telecommunications revolution would have been a non-event. Supporting the high growth telecommunications demand with copper, radio and satellite alone would have stalled the information revolution. These would not have made bandwidth and connectivity for all possible. Increasingly, therefore twisted pair copper cable is being replaced by optical fiber cable with new transmission technologies. The term access network has gained popularity after the advent of new technologies in the local loop. Another change which is now becoming evident is change of character of the access network from passive to active. These changes hold the promise of removing the limitations of the copper cable network.

A. Copper Networks

In the foreseeable future the subscribers in all sectors: government, residence, business, education and military will demand more and more enhanced services [2]. Demand for an integrated voice, video and data services is building up and very soon customers are not going to be satisfied even with the bandwidth the narrow band ISDN offers. The present network suffers from several limitations that make it inadequate to offer the customers all modern telecommunication services. Some of the significant limitations include: Limited bandwidth, inflexibility, limited reliability, long installation time, maintenance, passive network, losses,

Table 1. DSL Technologies

Applicability, interference, and security.

B. Copperaccess networks

A family of technologies that have begun to

Transform the narrow band copper access network into broadband network is the xDSL family of technologies. The term DSL, or digital subscriber line, refers to the modem which when connected at either ends of a normal twisted wire pair line, converts it into a digital line capable of handling data rates well into broad band [3]. The letter “x” indicates that there are many variants of DSL technology. Some of these are HDSL, SDSL, ADSL and VDSL.

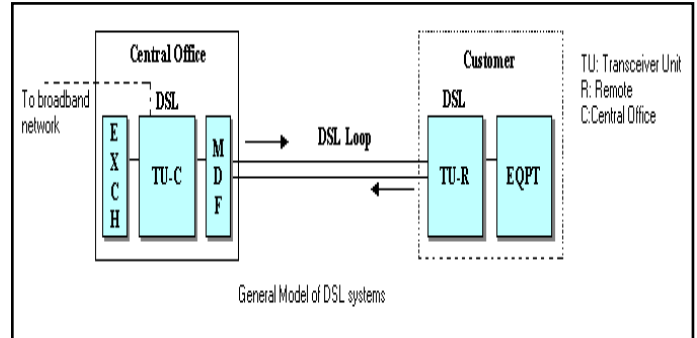

Fig. 2 : General Model of DSL systems

III. PON

Methods of deployment of fibre: -

The three methods, that are normally used, get their name from the location of the remote terminal equipment. Accordingly we have:

Fibre to the Curb (FTTC), in which the terminal equipment is located on the curb, from where it would be convenient to serve a suitable service area. Since the distribution would still be copper, suitable location for the terminal would be one which optimizes the cost, reduces back-feeding, reduces distribution cost and takes safety factors into consideration[4][5].

Fibre to the building (FTTB), in which the terminal equipment is located inside a multi-storeyed building, this brings higher bandwidth closer to the subscriber. The distribution part is still copper [6]. Fibre to the home/Office (FTTH/FTTO) in this .

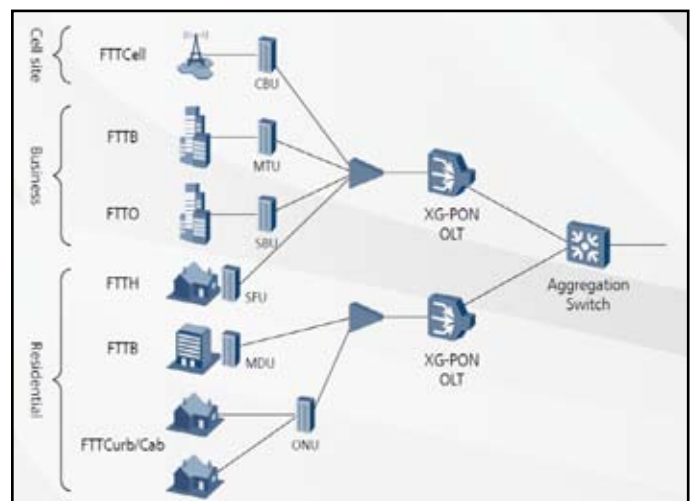

Fig. 3 : PON

Method the fibre goes up to the subscriber premises there are:

A. OFDMA PON

Implements orthogonal frequency division multiplexing in the electrical spectrum. Tuneable hybrid PON adopts tuneable transmitters and tuneable receivers in its terminals. These technologies are off the mainstream as there are serious cost bottlenecks due to technical complexity and immaturity. Most of them are under lab research. The PON industry does not anticipate fast revolution in the related areas of these technologies, and further research is needed [7].

B. CDMA PON

Both forward link and reverse link use PN Walsh code. PN code is used for timing synchronization. Walsh code is used for channel identification. A protocol control channel is used to compensate for the different lengths among channels for the reverse link. Receivers at OLT check the condition of synchronization and power from each ONU and send this information back to each ONU through the protocol channel. Each ONU align its timing according to the protocol channel [8].

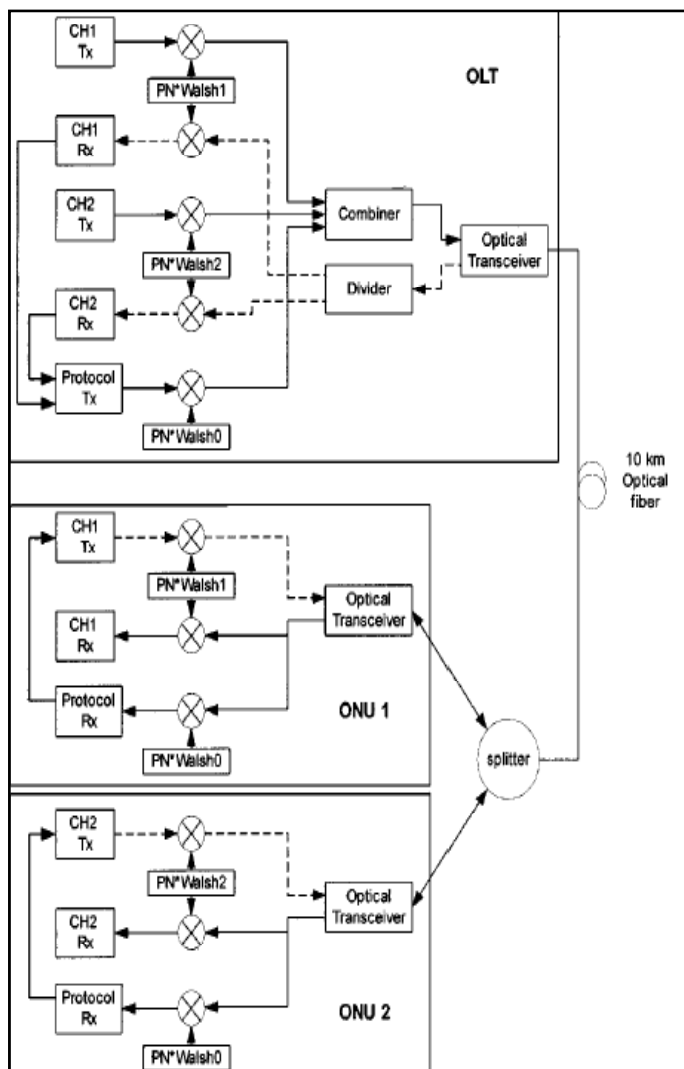

Fig.4 : CDMA.

IV. Related Issues

A. Dynamic Bandwidth Allocation

EPONs consist of one optical line terminal (OLT) situated at a central office and multiple optical network units (ONUs) located at the equipment at a customer’s premises. In the upstream direction

as it is a shared medium by ONUs, scheduling is required to prevent a data collision from different ONUs [9]. Thus dynamic bandwidth allocation (DBA) scheme is required to support better QoS in EPONs. Dynamic bandwidth assignment (DBA) can be on two Basis, inter-ONU scheduling and intra-ONU scheduling.

B. INTER-ONU Bandwidth Scheduling

A dynamic bandwidth allocation (DBA) scheme, an inter-optical network unit (ONU) bandwidth scheduling, is presented to provide quality of service (QoS) to different classes of packets in Ethernet passive optical networks (EPONs)[10]. These scheme are based on efficient threshold reporting from, and adaptive polling order rearranging of, ONUs.

C. INTRA- (ONU) Bandwidth Scheduling:

Dynamic Bandwidth Allocation algorithms and intra-ONU scheduling algorithms, These algorithms can be implemented in EPON in order to efficiently support the transmission of multimedia traffic and improve the performance of the low priority traffic at the same time. The system model separates the transmission of high priority traffic from the transmission of lower priority traffic and introduces the implementation of intra-ONU scheduling algorithms for lower traffic class transmission [11].

D. Noise and Crosstalk

Timing Jitters Noise: - The spontaneous emission noise of lumped optical amplifiers leads to timing Jitters. The timing jitters of the target pulses combining with the non-square shape of the switching window will result in the intensity fluctuation of the de-multiplexed pulses.

Crosstalk: - Crosstalk is distortion of channel caused by presence of another channel. There are two types of crosstalk inter channel and cross saturation. Inter channel cross talk is four way mixing effect (FWM). Which is non linear interference of two signals generates new signal in the form of noise. Cross saturation occurs when an semiconductor amplifier works is saturation mode. When a channel changes its state gain undergoes an opposite change.

V. Conclusion

PON is called passive because other than at the central office there is no active element within the access network. A PON enables a service provider to deliver a true triple play offering of voice, video and data, an important component of the data offering can be IPTV. PON are getting more widespread in rollout of Fiber To The Home (FTTH) infrastructure. Wavelength Division Multiplexing PON, or WDM-PON, is a type of passive optical networking, being pioneered by several companies, that uses multiple optical wavelengths to increase the upstream and/or downstream bandwidth available to end users. This technology looks forward to a day when optical technology is cheaper and easier to deploy, and end users demand higher bandwidth. WDM-PON can provide more bandwidth over longer distances by devoting more raw optical bandwidth to each user, and by increasing the link loss budget of each wavelength, making it less sensitive to the optical losses incurred at each optical splitter. To overcome the problem of increasing number of users DBA, inter and intra scheduling are used.

References

[1] E. Harstead and P. H. van Heyningen, "Optical access network, (2002)," in *Optical Fiber Communications IVB*,

- I. Kaminow and T. Li, Eds. New York: Academic.*
- [2] K. Cho, K. Fukuda, H. Esaki, and A. Kato, (2006), "The impact and implication of the growth in residential user-to-user traffic," in *Proc. CM/SIGCOMM Pisa, Italy, Sep. 11-15, 2006*, pp. 207-218..
- [3] D. Chrissan,(2004), "Uni-DSL: One DSL for universal service," *Texas Instruments White Paper (Spay018)*.
- [4] Lam, Cedric F., (2007) "Passive Optical Networks: Principles and Practice." *San Diego, California: Elsevier*.
- [5] Kramer, Glen,(2005), "Ethernet Passive Optical Networks," *McGraw-Hill Communications Engineering*.
- [6] P. Garvey,(2005), "Economics of FTTx in municipality overbuilds," *OSP (Outside Plant) Expo Technical Presentation*.
- [7] Dr. S.S. Riaz Ahamed,(2007), " OFDM for Data Communications," *IH, Pp 28-32*.
- [8] K. Takiguchi, T. Shibata, and H. Takahashi, (2006) "Time-spreading/ wavelength-hopping OCDMA experiment using PLC encoder/decoder with large spread factor," *Electronics Letters, Volume: 42 , Issue: 5 ,Page(s): 301 – 302*.
- [9] R. Mastrodonato, G. Paltenghi, (2005), "Analysis of a Bandwidth Allocation Protocol for Ethernet Passive Optical Networks (EPONs)," *Proc. of ICTON*, pp. 241-245.
- [10] B. Chen, J. Chen, S. He, (2006), "Efficient and Fine Scheduling Algorithm for Bandwidth Allocation in Ethernet Passive Optical Networks," *IEEE Journal of Quantum Electronics*, vol. 12, no. 4, pp. 183-187.
- [11] N. Ghani, A. Shami, C. Assi, M. Y. A. Raja, (2004), "Intra-ONU Bandwidth Scheduling in Ethernet Passive Optical Networks," *IEEE Communications Letters*, vol. 8, no. 11, pp. 683-685.

Author Profile



Neetu Singh received B.Tech degree in Electronics & Communication Engineering from Maharshi Dayanand University, Rohtak in 2012. She is currently an M.Tech student in the department of Electronics & Communication Engineering at Maharshi Dayanand University, Rohtak. Her current research interests include improvement of bandwidth efficiency of PON using PDF based DBA algorithm.